

FREEZETECH İÇ VE DIŞ TİCARET LİMİTED ŞİRKETİ

www.freezetechnology.com





As Freezetechnology team, we offer innovative solutions by designing and projecting in commercial type refrigerators, industrial cooling systems, industrial storage areas, store and market equipment. Founded by a team with more than 20 years of experience, Freezetechnology serves in many product groups that retailers need. With the concept of turnkey projects, Freezetechnology presents you closely following the effects of the rapid change in the world and in Turkey on the market and restaurant sector.

- www.freezetechnologytrade.com



OUR AREAS OF ACTIVITY

- 1) SUPERMARKET REFRIGERATION EQUIPMENT
 - 2) COOLING SYSTEMS
 - 3) COLD ROOM
 - 4) SUPERMARKET SHELF SYSTEMS
 - 5) HEAVY LOAD SHELVES
- AND MORE



SUPERMARKET REFRIGERATION EQUIPMENT

- 1) Half Height Vertical Cabinets
- 2) Full Length Vertical Type Cooler Cabinet
- 3) Vertical Frozen Glass Door Cabinets
- 4) Service Cabinets
- 5) Plug-in Series



Technical Specifications / Technische Angaben

Low Emission / Düşük Emisyonlar
Energy-Saving Fan / Enerji Tasarruflu Fan
Loading Capacity / Artırılmış Yükleme Kapasitesi
Anetling Doors / Aralık Kapılar
Covers Available / Opsiyonel Kapaçlar
Visibility / Artırılmış Görünürlük
Small Footprint / Düşük A2 Baskıya
Bar Led
Tube Led
Doors Available / Opsiyonel Kapılar
Micro Ventilation / Mikro Havalandırma
Sliding System / Kayanlı Sistem / Kapak

Refrigerants / Soğutucu Gazlar

R290 / Green Energy
R449a / Environmentally Friendly
CO₂ / Environmentally Friendly
R404A / Environmentally Friendly
R448A / Environmentally Friendly
R410A / Environmentally Friendly
R134A / Environmentally Friendly
R452A / Environmentally Friendly
R1270 / Environmentally Friendly

Serve Over Counters Glass Types / Şarküteri Cam Opsiyonları

Curved Glass / Bombé Camı
Flat Glass / Düz Camı
Inclined Flat Glass / Açı Düz Camı
Wardrobe Flat Glass / Gardırop Düz Camı

Abbreviations / Tanımlamalar

DP : Şarküteri Ürünleri / Dairy Products	SS : Self Servis / Self Service	PR : Pastry Refrigerated
MT : Et Ürünleri / Meat Products	CB : Kapalı Ayak / Closed Bottom	PN : Pastry Neutral
FV : Meyve ve Sebze / Fruit and Vegetables	OF : Blok Ayak / Open Feet	SB : Salad Bar
	AD : Alüminyum Dekor / Aluminium Decoration Trim	BM : Bain Marie
	SD : Sac Dekor / Sheet Metal Decoration Trim	HP : Hot Plate
	IC : İç Köşe / Internal Corner	SP : Special
	OC : Dış Köşe / Open Corner	
FG : Düz Cam / Flat Glass		
CG : Bombeli Cam / Curved Glass		
IFG : Eğimli Düz Cam / Inclined Flat Glass		
WFG : Menteşeli Düz Cam / Hinged Flat Glass		



Dairy Products Kühlregal

LION V2/110/220-205

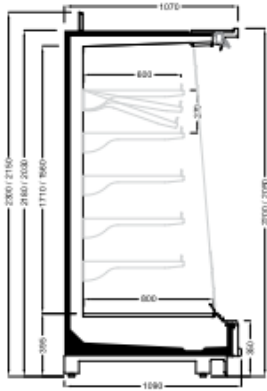

LION V2/100/220-205

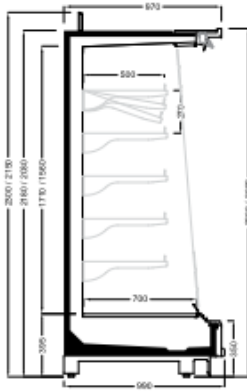

LION V2/90/220-205

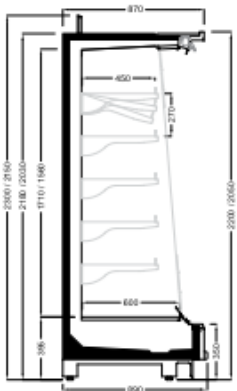

LION V2/75/220-205

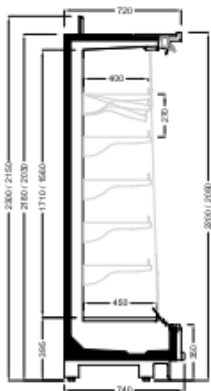

Packed Meat Paket und

LION V2 MT /110/220-205

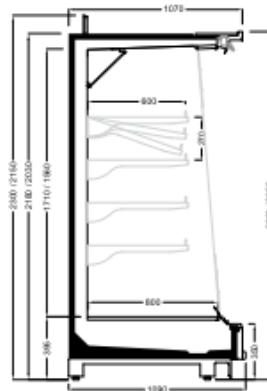

LION V2 MT /100/220-205

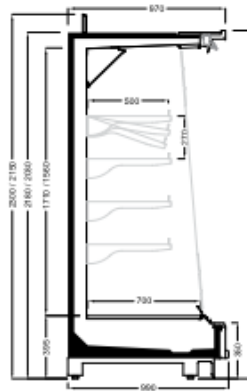

LION V2 MT /90/220-205

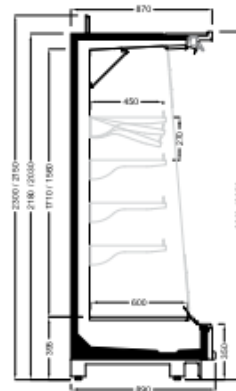

LION V2 MT /75/220-205

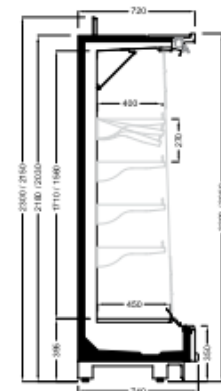

Fruits & Vegetables Gemüse und Obst

LION V2 FV/110/220-205

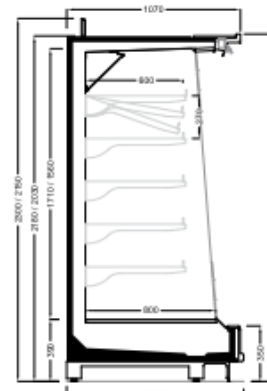

LION V2 FV/100/220-205

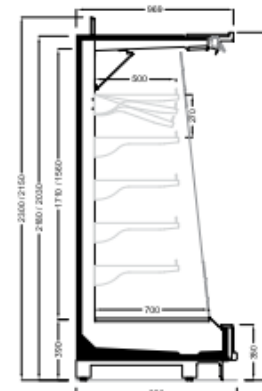

LION V2 FV/90/220-205

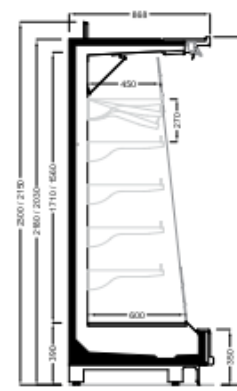

LION V2 FV/75/220-205

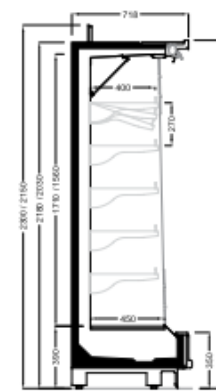

Freezetechn

About the product

Operating Temperatures / Betriebstemperaturen			Ambient Conditions Umgebungsbedingungen
DP	MT	FV	
M2 (-1/+7°C)	M1 (-1/+5°C)	H1 (+1/+10°C)	25°C / 60% RH (EN ISO 23953-2)

Available Modules / Verfügbare Module					
Length/Länge (mm)	1250	1875	2500	3750	Gondola / Head
Side panel/ Seitenabdeckung (mm)	40	40	40	40	40



LION TGD
 Refrigerated Multideck Cabinet
 Transparent Glass Hinged Door
 Duvar Tipi Soğutucu Reyon
 Şeffaf Isıcamlı Çarpma Kapılı

Operating Temperatures / Betriebstemperaturen			Ambient Conditions Umgebungsbedingungen
DP	MT	FV	
M2 (-1/+7°C)	M1 (-1/+5°C)	H1 (+1/+10°C)	25°C / 60% RH (EN ISO 23953-2)

Available Modules / Verfügbare Module					
Length/Länge (mm)	1250	1875	2500	3750	Gondola / Head
Side panel/ Seitenabdeckung (mm)	40	40	40	40	40

Technical Specifications / Technische Angaben

Categories / Kategorien



About the product



Operating Temperatures / Betriebstemperaturen		Ambient Conditions Umgebungsbedingungen
DP	MT	
M2 (-1/+7°C)	M1 (-1/+5°C)	25°C / 60% RH (EN ISO 23953-2)

Available Modules / Verfügbare Module					
Length/Länge (mm)	1250	1875	2500	3750	Gondola / Head
Side panel/ Seitenabdeckung (mm)	40	40	40	40	60



About the product



Available Modules / Verfügbare Module				
Length (mm) Länge (mm)	2D 1562	3D 2343	4D 3124	5D 3905
Side panel (mm) Seitenabdeckung (mm)	50	50	50	50
Operating Temperatures Betriebstemperaturen		Ambient Conditions Umgebungsbedingungen		
L1 (-15/-18°C) - L2 (-12/-18°C)		25°C / 60% RH (EN ISO 23953-2)		



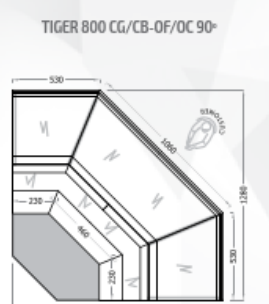
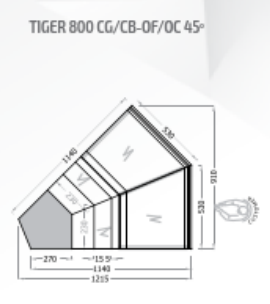
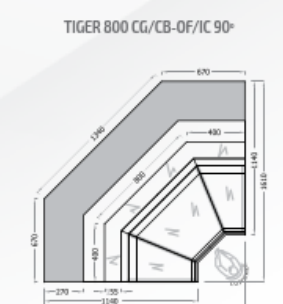
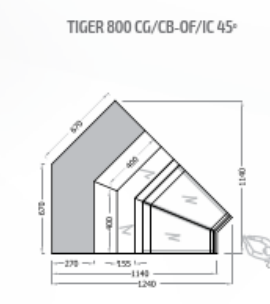
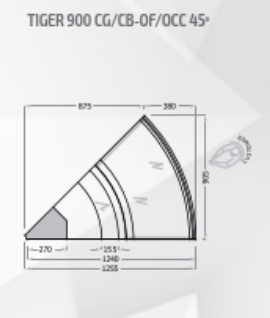
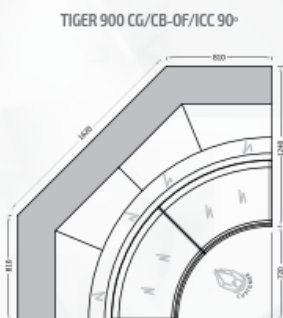
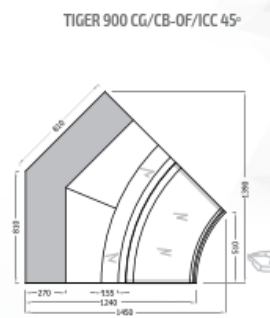
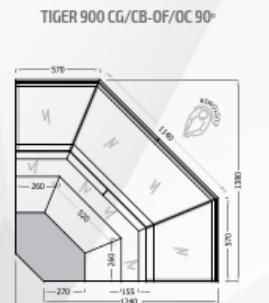
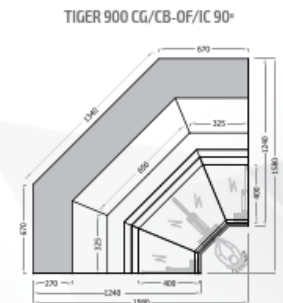
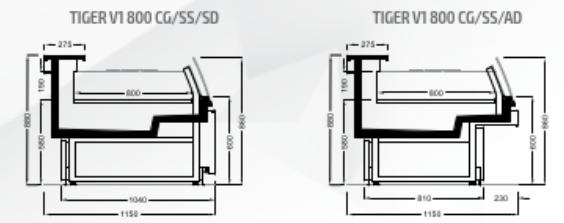
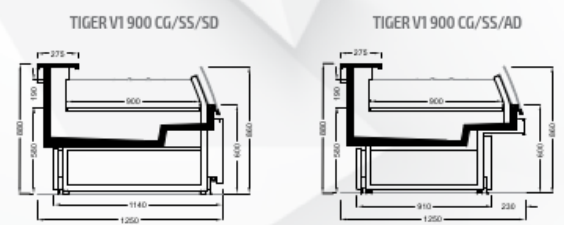
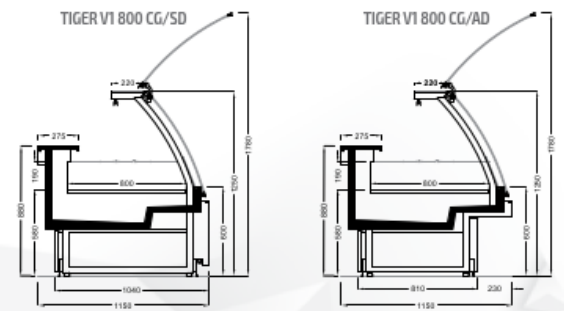
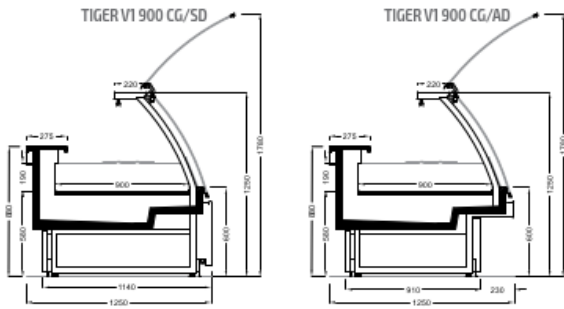

Serve-Over Counters
Freistehend



About the product

Available Modules / Verfügbare Module						
Length (mm) Länge (mm)	937	1250	1875	2500	3750	Corner Modules Köşe Modüller
Side panel (mm) Seitenabdeckung (mm)	40	40	40	40	40	40
Operating Temperatures Betriebstemperaturen			Ambient Conditions Umgebungsbedingungen			
M1 (-1/+5°C) - M2 (-1/+7°C)			25°C / 60% RH (EN ISO 23953-2)			



About the product

Available Modules / Verfügbare Module					
Length (mm) Länge (mm)	1875	2500	3750	2000 HD	1500 HD
Side panel (mm) Seitenabdeckung (mm)	60	60	60	60	60
Operating Temperatures Betriebstemperaturen			Ambient Conditions Umgebungsbedingungen		
L1 (-15/-18°C) - L2 (-12/-18°C)			25°C / 60% RH (EN ISO 23953-2)		



About the product

Available Modules / Verfügbare Module	
Length (mm) Länge (mm)	1050
Operating Temperatures Betriebstemperaturen	Ambient Conditions Umgebungsbedingungen
M1 (-1/+5°C) - M2 (-1/+7°C)	25°C / 60% RH (EN ISO 23953-2)

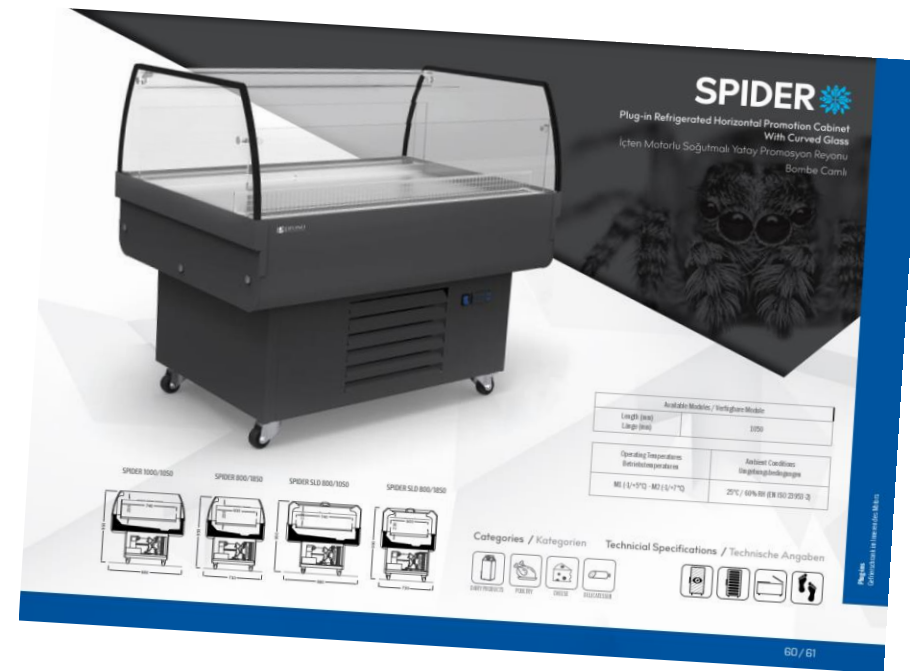

About the product

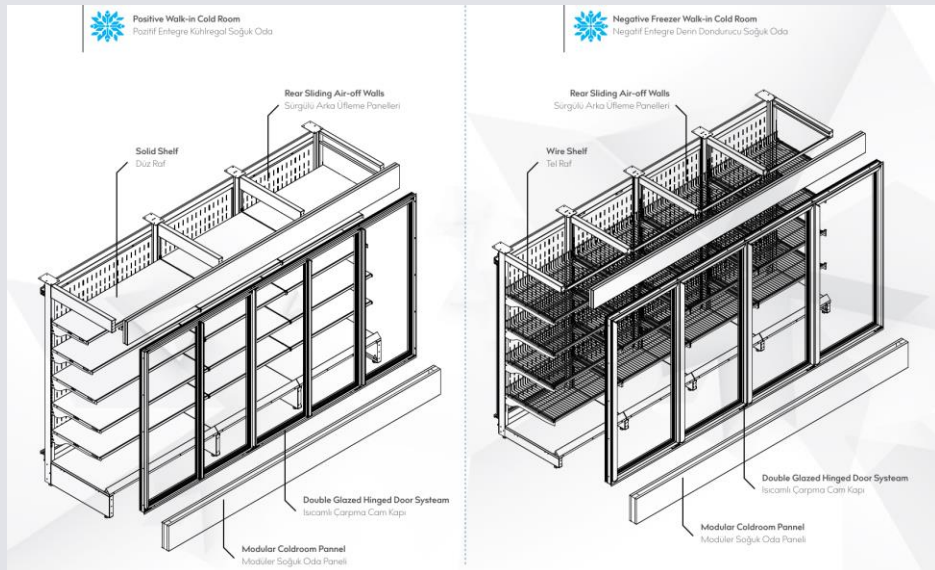

Meat, milk, fruits and vegetables, bakery products, various frozen products, all kinds of food products like ice cream can be stored under the best Conditions and for the longest time possible in our cold storage rooms that are constituted with locked sandwich panels, which have been prepared with 42 kg/m³ density polyurethane. Our cold storage rooms, which could also be produced with glass doors, depending on your request could be used inside of the store for the purpose of both storing and for displaying.

- AISI 304, PVC coating or powder coated sheet metals can be used on internal and external surfaces of panels, depending on your request.
- Our panels can be produced in thicknesses of 80 mm, 100 mm, 120 mm, 160 mm and in 200 mm.
- In our cold storage rooms, which could also be set up with Atmospheric Control System depending on the requirements for large fruit and vegetable storage, fruits and vegetable can be stored under the most appropriate Conditions with the use of this system.
- While the corner panel, which can be manufactured as single piece, provides ease of assembly, it would also provide efficiency for the consumption of the energy at the same time as it provides much better insulation for your cold storage rooms.
- There are options of swing, sliding, monorail, sectional, flip-flap, fast passage and atmospheric controlled doors available depending on the requirements.



Cold Room Doors / Soğuk Oda Kapıları



Modular Cold Room / Modüler Soğuk Oda



- Meat, milk, fruits and vegetables, bakery products, various frozen products, all kinds of food products like ice cream can be stored under the best Conditions and for the longest time possible in our cold storage rooms that are constituted with locked sandwich panels, which have been prepared with 42 kg/m³ density polyurethane. Our cold storage rooms, which could also be produced with glass doors, depending on your request could be used inside of the store for the purpose of both storing and for displaying.
- AISI 304, PVC coating or powder coated sheet metals can be used on internal and external surfaces of panels, depending on your request.
 - Our panels can be produced in thicknesses of 80 mm, 100 mm, 120 mm, 160 mm and in 200 mm.
 - In our cold storage rooms, which could also be set up with Atmospheric Control System depending on the requirements for large fruit and vegetable storage, fruits and vegetable can be stored under the most appropriate Conditions with the use of this system.
 - While the corner panel, which can be manufactured as single piece, provides ease of assembly, it would also provide efficiency for the consumption of the energy at the same time as it provides much better insulation for your cold storage rooms.
 - There are options of swing, sliding, monorail, sectional, flip-flap, fast passage and atmospheric controlled doors available depending on the requirements.



Modular Cold Room / Modüler Soğuk Oda



Application Types

- Split-Type Refrigeration Units
- Open Type Condensing Units
- Mono Block Refrigeration Units
- Twin Central Refrigeration Systems
- Chiller Units
- Tandem Cooling Systems

Options

- Invertor Application
- Electronic fan speed control system
- Control from one center by connecting to central automation systems
- Co2 Cooling System
- Heat Exchanger Application
- Heat recovery Applic



Advantages

- In models with a cabin, body of the device is covered with electrostatic powder paint resistant to outer Conditions and has decorative appearance.
- Low cost initial investment.
- High refrigeration performance, wide range of capacity and Permanency of refrigeration.
- 30-35 % energy saving.
- Minimum space occupation.
- Easy installation, maintenance and service.
- Easy programming to requested values.
- Control from one cente by connecting to central automation systems.

CHILLER UNITS

These are the units designed to meet process water-cooling needs of numerous sectors, such as air conditioning, plastics, packing, chemistry, pharmaceuticals, and food. Cold-water units

can be manufactured with cold-water output temperature ranging from +2 °C to +10 °C, according to request. The system is designed with suitable capacity depending on need and load and made up of 1 to 4 semi-hermetic compressors. The elements of a cooling group are optimally located and designed to have the minimum sizes. Operation of compressor and condenser fans is carried out by a microprocessor according to data received from sensors depending on capacity. Upon request, the system operation can be observed and simple interference can be carried out from any remote center by means of connection to control panel through a data line. Power feeding and control panel are located on the unit and all connections are fi nished at the factory.

General Equipments

All types are supplied with the following equipment.

- Semi-hermetic or hermetic compressors.
- Oil separator, oil collector, oil pressure control valve, low and high pressure control automat, on the basis of one per a system.
- Discharge suction line vibration receivers, low and high pressure control automats, and oil level regulators in all compressors.
- Refrigeration liquid collector.
- Humidity receiver fi lters on liquid and return lines.
- Horizontal type liquid accumulator.
- Check valve and ball valves.



Warehouse Shelf Systems

Depo Raf Sistemleri Warehouse Rack Systems

B	H	PROFIL Profile	B	H	PROFIL Profile	B	H	PROFIL Profile	B	H	PROFIL Profile	B	H	PROFIL Profile	B	H	PROFIL Profile
1050	2000	120X3mm	1050	2000	120X2.5mm	1050	2000	120X2mm	1050	2000	98X2.5mm	1050	2000	88X2mm	1050	2000	80X2mm
1050	2500	120X3mm	1050	2500	120X2.5mm	1050	2500	120X2mm	1050	2500	98X2.5mm	1050	2500	88X2mm	1050	2500	80X2mm
1050	3000	120X3mm	1050	3000	120X2.5mm	1050	3000	120X2mm	1050	3000	98X2.5mm	1050	3000	88X2mm	1050	3000	80X2mm
1050	3500	120X3mm	1050	3500	120X2.5mm	1050	3500	120X2mm	1050	3500	98X2.5mm	1050	3500	88X2mm	1050	3500	80X2mm
1050	4000	120X3mm	1050	4000	120X2.5mm	1050	4000	120X2mm	1050	4000	98X2.5mm	1050	4000	88X2mm	1050	4000	80X2mm
1050	4500	120X3mm	1050	4500	120X2.5mm	1050	4500	120X2mm	1050	4500	98X2.5mm	1050	4500	88X2mm	1050	4500	80X2mm
1050	5000	120X3mm	1050	5000	120X2.5mm	1050	5000	120X2mm	1050	5000	98X2.5mm	1050	5000	88X2mm	1050	5000	80X2mm
1050	5500	120X3mm	1050	5500	120X2.5mm	1050	5500	120X2mm	1050	5500	98X2.5mm	1050	5500	88X2mm	1050	5500	80X2mm
1050	6000	120X3mm	1050	6000	120X2.5mm	1050	6000	120X2mm	1050	6000	98X2.5mm	1050	6000	88X2mm	1050	6000	80X2mm
1050	6500	120X3mm	1050	6500	120X2.5mm	1050	6500	120X2mm	1050	6500	98X2.5mm	1050	6500	88X2mm	1050	6500	80X2mm
1050	7000	120X3mm	1050	7000	120X2.5mm	1050	7000	120X2mm	1050	7000	98X2.5mm	1050	7000	88X2mm	1050	7000	80X2mm
1050	7500	120X3mm	1050	7500	120X2.5mm	1050	7500	120X2mm	1050	7500	98X2.5mm	1050	7500	88X2mm	1050	7500	80X2mm
1050	8000	120X3mm	1050	8000	120X2.5mm	1050	8000	120X2mm	1050	8000	98X2.5mm	1050	8000	88X2mm	1050	8000	80X2mm
1050	8500	120X3mm	1050	8500	120X2.5mm	1050	8500	120X2mm	1050	8500	98X2.5mm	1050	8500	88X2mm	1050	8500	80X2mm
1050	9000	120X3mm	1050	9000	120X2.5mm	1050	9000	120X2mm	1050	9000	98X2.5mm	1050	9000	88X2mm	1050	9000	80X2mm
1050	9500	120X3mm	1050	9500	120X2.5mm	1050	9500	120X2mm	1050	9500	98X2.5mm	1050	9500	88X2mm	1050	9500	80X2mm
1050	10000	120X3mm	1050	10000	120X2.5mm	1050	10000	120X2mm	1050	10000	98X2.5mm	1050	10000	88X2mm	1050	10000	80X2mm

B	H	PROFIL Profile
400	500	60X1.5mm
400	600	60X1.5mm
400	700	60X1.5mm
400	800	60X1.5mm
400	900	60X1.5mm
400	1050	60X1.5mm
500	500	60X1.5mm
500	600	60X1.5mm
500	700	60X1.5mm
500	800	60X1.5mm
500	900	60X1.5mm
500	1050	60X1.5mm
600	500	60X1.5mm
600	600	60X1.5mm
600	700	60X1.5mm
600	800	60X1.5mm
600	900	60X1.5mm
600	1050	60X1.5mm
700	500	60X1.5mm
700	600	60X1.5mm
700	700	60X1.5mm
700	800	60X1.5mm
700	900	60X1.5mm
700	1050	60X1.5mm
800	500	60X1.5mm
800	600	60X1.5mm
800	700	60X1.5mm
800	800	60X1.5mm
800	900	60X1.5mm
800	1050	60X1.5mm
900	500	60X1.5mm
900	600	60X1.5mm
900	700	60X1.5mm
900	800	60X1.5mm
900	900	60X1.5mm
900	1050	60X1.5mm
1000	500	60X1.5mm
1000	600	60X1.5mm
1000	700	60X1.5mm
1000	800	60X1.5mm
1000	900	60X1.5mm
1000	1050	60X1.5mm

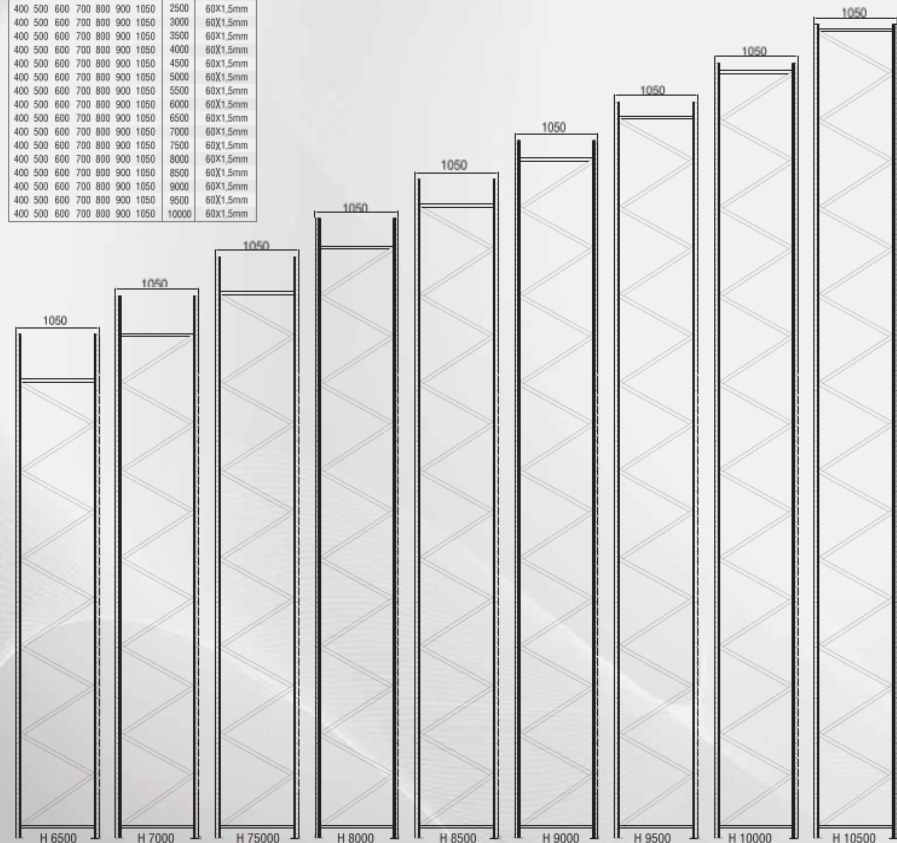

Warehouse Shelf Systems



• www.freezetechnology.com

Super Market Shelf Systems

Market Raf Sistemleri Market Shelf Systems



Çift Yönlü Orta Ünite
Double Side Gondola Unit

Kod / Code 20 00 00337
Ölçü / Dimension 40X100X180
Özellik / Feature 40A/4X30

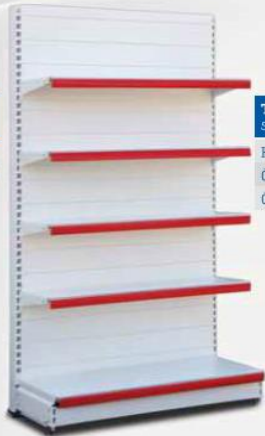

Tek Yönlü Orta Ünite
Single Side Gondola Unit

Kod / Code 20 00 00371
Ölçü / Dimension 40X100X180
Özellik / Feature 40A/4X30



Çift Yönlü Orta Ünite
Double Side Gondola Unit

Kod / Code 20 00 00334
Ölçü / Dimension 40X100X180
Özellik / Feature 40A/3X30
Aksesuarlar dahil değildir.

Ön Siperlik
Brimmed

Kod / Code 20 00 S0009
Ölçü / Dimension 100 cm



Tek Yönlü Orta Ünite
Single Side Gondola Unit

Kod / Code 20 00 00368
Ölçü / Dimension 40X100X180
Özellik / Feature 40A/3X30
Aksesuarlar dahil değildir.



9016 Beyaz 9001 Krem 7035 Gri 7046 Koyu Gri 1003 Sarı 5018 Yeşil 5002 Mavi 2004 Turuncu 3000 Kırmızı 9005 Siyah

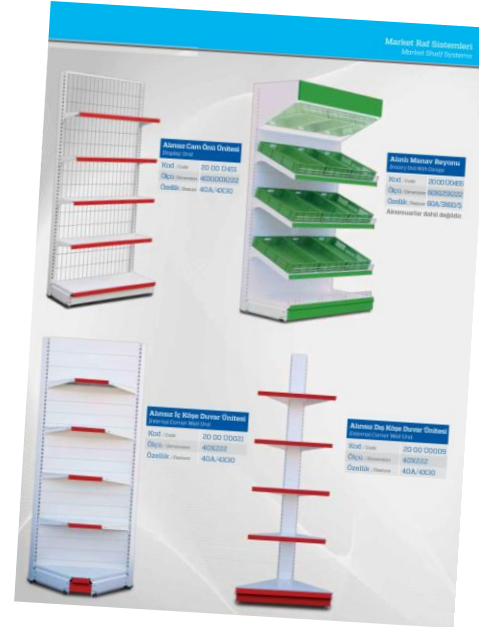

Market Raf Sistemleri
Market Shelf Systems



Market Raf Sistemleri
Market Shelf Systems



Market Raf Sistemleri
Market Shelf Systems

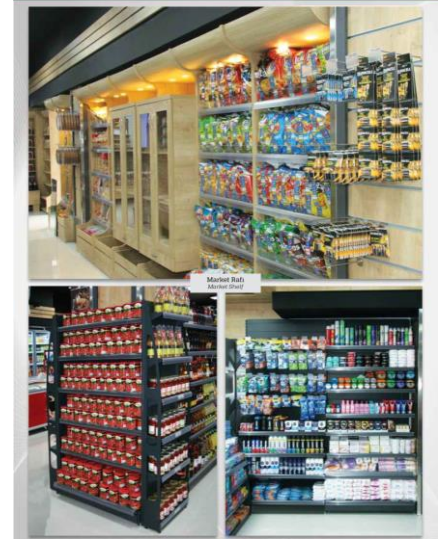

Market Raf Sistemleri
Market Shelf Systems



Market Raf Sistemleri
Market Shelf Systems



Market Raf Sistemleri
Market Shelf Systems



Yarım Daire Gondol Başı (H:138 cm)
Half Circle Head Gondola

Kod / Code	20 00 ST040
Ölçü / Dimension	40X138



Gondol Başı Yan Stand (H:180 cm)
Gondola Side Stand

Kod / Code	20 00 ST022
Ölçü / Dimension	53X180

Gondol Başı Yan Stand (H:180 cm)
Gondola Side Stand

Kod / Code	20 00 ST022
Ölçü / Dimension	53X180

Gondol Başı Yan Stand (H:180 cm)
Gondola Side Stand

Kod / Code	20 00 ST022
Ölçü / Dimension	53X180



Market Raf Sistemleri
Market Shelf Systems



Bakery Mamül Üniteleri
Bakery Units



Bakliyat Üniteleri
Pulse Units



Kitaplık ve CD'lik Üniteleri
Magazine and CD Unit



Market Rafı
Market Shelf



Yazar Kasa Altları
Check Out Counters



Kasa Altı
Without Belt



Doner Turnike
Revolving Turnstile



Yaprak Turnike Seti
Leaf Turnstile Set



Yon Profil Havuz
in Gondola



Promosyon Tel Derin Havuz
Deep Promotion Gondola



İkili Ekmek Dolabı
Double Bread Cupboard



Tekli Ekmek Dolabı
Single Bread Cupboard



Market Rafı
Market Shelf



Suntalam Orta Reyon



El Sepeti
Hand Basket

Plastik El Sepeti
Plastic Hand Basket



Mağaza Raf Sistemleri
Store Shelf Systems



Ahşap Manav Ünitesi
Wooden Grocery Unit



Ahşap Manav Ünitesi
Wooden Grocery Unit

APPLICATION PICTURES

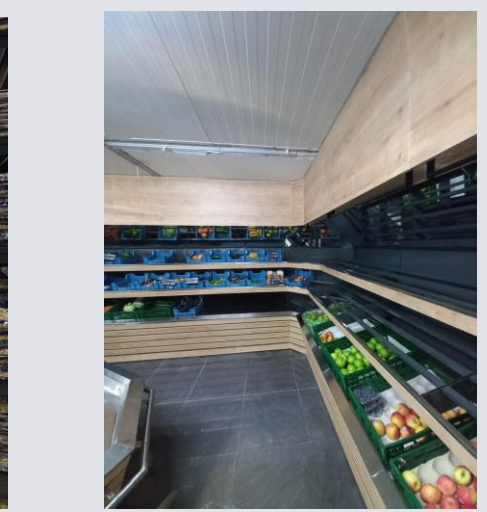
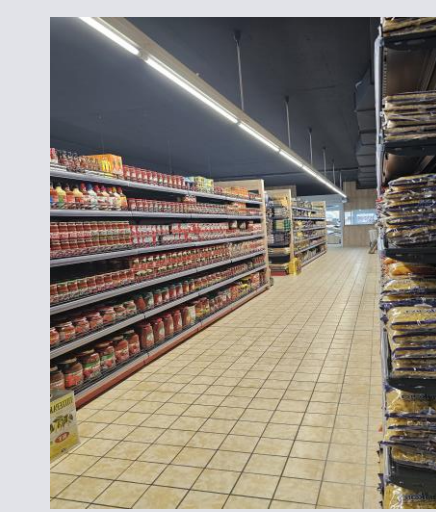
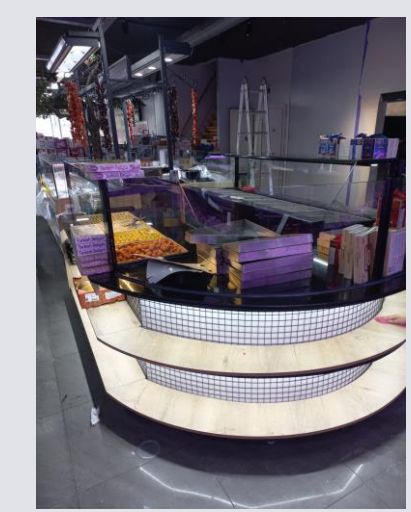

APPLICATION PICTURES

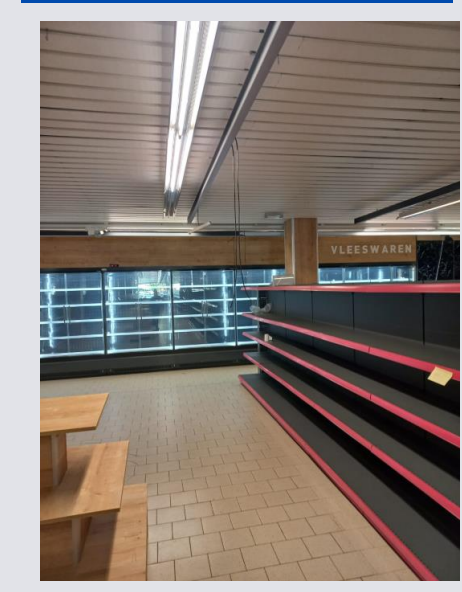

FREEZETECH İÇ VE DIŐ TİCARET LİMİTED ŐİRKETİ Adres:

- BEYLİKDÜZÜ / İSTANBUL

iletisim:

- +90 549 829 00 17
- hakan@freezetechnade.com

